

Test Boxes

5 YEAR
WARRANTY



Test Boxes - GW0005, GW0010 & GW0020

- User-friendly and reliable portable testing box for testing Safety Relief Vents
- Easy to read digital compound gauges register both pressure and vacuum settings
- Training available upon request



Girard Test Boxes

FEATURES

The Girard Test Box is a user-friendly, portable all-in-one testing box for testing Safety Relief Vents. It is configured for both pressure and vacuum testing. Multiple connections are available to test a variety of pressure relief devices. Constructed of steel. The pressure regulator allows shop air pressure to be adjusted. There is an easy to read NIST digital compound gauge that registers both pressure and vacuum settings. Includes two selector valves; one to apply or release air pressure, and one to allow user to select for pressure or vacuum testing. Manufactured and assembled in the USA.

MODEL	DESCRIPTION
GW00005	4" NPT Male Connection
GW00010	2.5" BSP Female Connection
GW00020	3" NPT Male Connection

GW00005 / GW00010

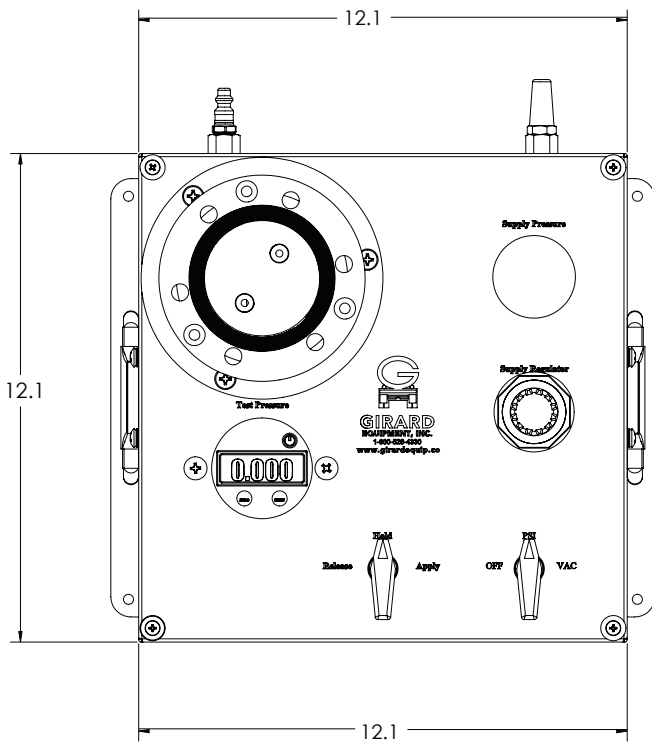

GW00005

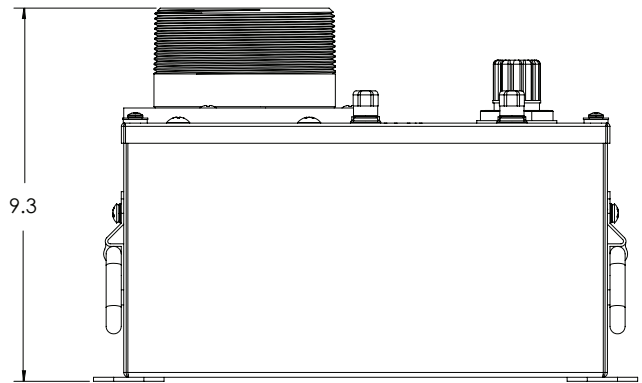

GW00010

